

## Smart Safety Device for Women Using IOT

Punamchand Gumladu<sup>1</sup>, Tanaya Kulkarni<sup>2</sup>, Pooja Waghmare<sup>3</sup>, J. A. Gurav<sup>4</sup>

<sup>1,2,3</sup>(Final Year Students, Department of Electrical engineering, ZCOER, Pune, Maharashtra)

<sup>4</sup>(Assistant Professor, Department of Electrical engineering, ZCOER, Pune, Maharashtra)

### Abstract:

Now a days, women and children are facing various issues like sexual assaults. Such violence will definitely have huge impact on the lives of victim. It also affects their health and their psychological balance. These kinds of violence keep on increasing day by day. Even school children are kidnapped and sexually abused. We are living in a society where a nine months old girl child doesn't have security; the child was kidnapped, raped and then murdered.

On witnessing those violations against women, its impulses us to do something for women and children safety. So, in this paper we have planned to propose a device which will act as a tool to provide security and ensures the safety of the women and the children. Microcontroller, GSM and GPS module are used to send notifications and current location of women to various mobile numbers in their contact.

**Keywords** — Women safety, Screaming, Global mobile communication system, Global positioning system.

### 1. INTRODUCTION

In today's world, women safety has become a major issue as they can't step out of their house at any given time due to physical/ sexual abuse and a fear of violence. Even in the 21st century where the technology is rapidly growing and new gadgets were developed but still women's and girls are facing problems. Women are adept at mobilizing diverse groups for a common reason.

The Daily Star published a news on Nov 7, 2021 about a brave girl from Bangladesh, who jumped off a moving bus to avoid being raped. This brave girl was travelling in a bus and could sense imminent danger. When the driver attempted to rape her, she jumped of the bus and was saved by another car driver. Just like this scenario, women face immense threat of sexual harassment in the streets, as rapists target them to become their victim. So, their safety is a global issue at the moment. According to a report by Odhikar, a Bangladeshi human rights organization, gang rape cases in the street have nearly tripled from under 100 in 2007 to nearly 300 by the year 2021.

In the year 2021 alone, around 3700 women and children in Bangladesh were victims of sexual abuse including rape and murder. In today's society,

such cases are all too common, which is unacceptable. We need more courageous girls like her who can protect themselves from these criminals. To empower women, we researched in this area and decided to build a safety device which can be used in these kinds of scenarios. On the other hand, even if the situation is against her, the device can take action using her vital signs such as heart-beat and oxygen levels. For this, we need a wireless device. That is when IoT comes for solving the problem, and that is what this research paper focuses on. This paper discusses the functionality of a wireless IoT device that can provide safety for women while they are in any dangerous situation. The devices here can communicate using IoT.

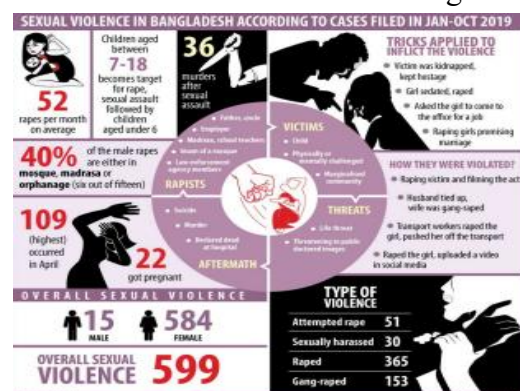

Fig 1.1: Statistics of sexual violence

The working model here, is a device that sends alerts via text using the GSM cellular method, relay's location coordinates via GPS, and generates an alarm. Wirelessly transferring data from the sensor to a cloud platform which allows monitoring of current data. This equipment is set up to continuously monitor women's vital parameters like pulse rate and temperature [3], and activate automatically if a dangerous scenario arises. It is easy to wear as the material is flexible and non-irritating for the skin and adjustable enough to ensure a comfy fit. This new technology is built in such a way that it serves its purpose to the fullest, which is ensuring women's safety and providing an active lethal form of self-defense.

## **2. RESEARCH OBJECTIVE**

In the last 20 years, Bangladesh has made remarkable prosperity in the sector of women empowerment. According to Dhaka Tribune, the number of working women rose from 16 million in 2010 to 18.5 million in 2016-17. Bangladesh ranked 47th out of 144 nations in 2017 according to the Global Gender Gap Report. Unfortunately, as the number of working women continue to rise, so does violence, sexual assaults and rape put women's security at risk. The horrific rape cases and sexual assaults on women in the streets have shown us that the present crisis cannot be solved by relying solely on the country's law and order. One of the most shocking cases of rape and murder in this scenario is the rape of Shohagi Jahan Tonu who was raped and later murdered in one of the most secured places in Bangladesh, military cantonment.

While researching on this case we found out that, when Tonu did not return home after tutoring her student, her father started to look for her and unfortunately, she was found dead in a devastated condition. Later found out that she was raped before murdered. Even though two autopsies were performed on her and mass protest took place in Bangladesh, we could not bring justice for Tonu. Anyone could blindly say that the case was dismissed by the powerful party. Proper evidence could be the biggest power of any kind of rape case to bring justice.

Considering the above cases, we realized that only depending on the laws doesn't solve the

problem. We need to take the responsibility of our security in our own hand. Therefore, we decided to build a device that can alert nearby people with a buzzer, send location via message to close one and they can keep an eye by using live-streaming and also save the live for future purpose. Here comes the objective of our device: To build a wireless, small and comfortable device that can be easily wearable by girls going outside.

Choosing appropriate sensors to detect fear or any unexpected situation such as harassment, rape etc.

To accommodate all the components together we need to choose a suitable microcontroller that can work properly.

To choose the proper IoT server this will be used for our data management, data collection and so on. The device will not only be used as defense system but also to reach out to the family members to locate the victim, preserve evidence via live streaming for future use as well.

## **3. LITERATURE SURVEY**

Shaista Khanam, Trupti Shah [1] proposed algorithm for women safety using fingerprint module. This paper gives a detailed approach towards women safety. Here fingerprint is required for activation of device, electric shock producing circuit, GSM and GPS module for alerting and location tracking. At the time of emergency, it is hard to place the finger in the fingerprint module and recognition is not possible, if there is any undesired stuff (wet or dust) in the finger. To avoid this problem the fingerprint module will not be used in the proposed system.

Naeemul Islam, Md. Anisuzzaman, Sikder Sunbeam Islam, Mohammed Rabiul Hossain, Abuja far Mohammad Obaidullah [2] developed a device for safety and protection of women. Here three push buttons are implemented to define the types of accident victim is facing. To control a whole system a PIC16F887A microcontroller is used. Since it is a 40 pin IC, it increases the size of the device, which will make it difficult for women/children to carry all the time.

Sharifa Rania Mahmud, Jannatul Mayowa, Ferry Wahyu Wibowo [3] proposed an algorithm for women empowerment. This paper discusses about

violence against women and also different health issues of women. It is an application-based system. During the event of molestation using the application present in the victim's smartphone will automatically send out an emergency call to the assigned contacts. This can do only when GPS is enabled in the smartphone and if not, the time delay taken to turn on the GPS is noted to be the downside of the paper.

Many devices are now available in the market which are meant for the safety of women and some of which are still in the development stage. "Suraksha"-A Women Safety device [3] is a security system specially designed for women in distress. The basic purpose of the system is to intimidate instant location and a distress message is sent to the cops or to registered numbers, so that unfortunate incidents would be averted and will also provide real time evidence for swift action against the perpetrators of crime against woman. It is capable of location tracking and screams an alarm when blood pressure of wearer exceeds a limit. The size of the system is more and the pressure sensors used are usually too expensive. Also, the device is bulky and the system needs a receiver transmitter system with wireless module and GSM module for communication, Smart Girls Security System [4].

#### 4. PROPOSED SMART SAFETY DEVICE

In the past system, the women's alerting system is implemented. The applications contain the SOS number for the purpose of security which warns the victims' family members. Many developers have creative applications that take this concern into consideration. Emergency service code that alerts police control is used to provide emergency services. The free "Help me mobile" mobile app has been launched to ensure the safety of women in an emergency. In order to do this, these applications require one click. But if a girl is in trouble, the girl may sometimes not be able to call and push the button.

This paper describes about a one touch alarm system for women's safety using GSM. In the light of recent outrage in Delhi which shook the nation and woke us to the safety issues for women, people are finding up in different ways to defend. Here we

introduce a device which ensures the protection of women. This helps to identify protect and call on resources to help the one out of dangerous situations. Anytime you sense danger, all you had to do, is hold on the button of the device. The device consists of a microcontroller, GSM module, GPS modules. The system resembles a normal watch which when activated, tracks the place of the women using GPS (Global Positioning System) and sends emergency messages using GSM (Global System for Mobile communication), to selected contacts and the police control room. The main advantage of this system is that the user does not require a Smartphone unlike other applications that have been developed earlier. The use of sophisticated components ensures accuracy and makes it reliable.

#### 4.1 WOMEN SAFETY DEVICE

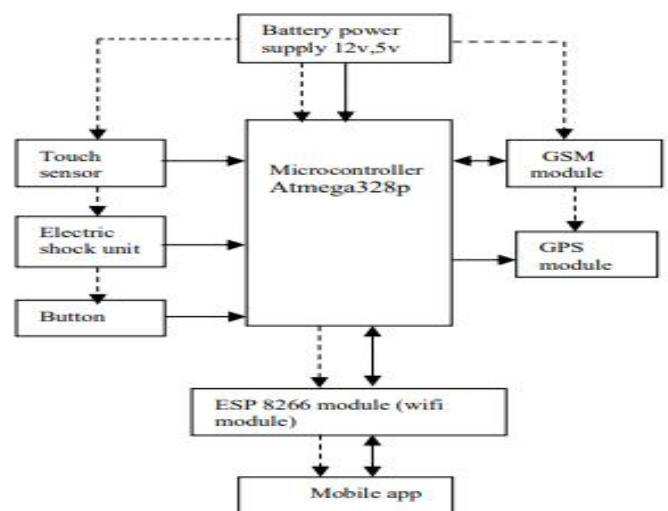

Fig 4.1: Architecture of design

The ultimate aim of the paper is to developed a self defence device. Whenever there is an emergency, she has to press the button. Then the electric shock unit and the touch sensor gets activated. The High voltage Low current shock circuit will stun the opposition for few seconds, which acts as a self defence. An intimation along with the location will be sent to the contact mobile numbers of the person.

Fig. 4.1 shows the block diagram of IoT based smart security and safety system for women and children. Microcontroller, Arduino no is used for interfacing with peripherals. SIM 900 GSM and GPS are used to send notification along with

location. Electric shock circuit is used to generate high voltage low current to paralyses the opponent for few seconds.

In the proposed system we here designed equipment for alerting the system. In this paper we here used the Arduino controller for the controlling the whole process of the system. The GSM is used to send SMS regarding GPS locations. LCD is for displaying and switch is pressed when the person is in danger. Here we are adding Buzzer Laser Diode which will activate when the women press the switch.

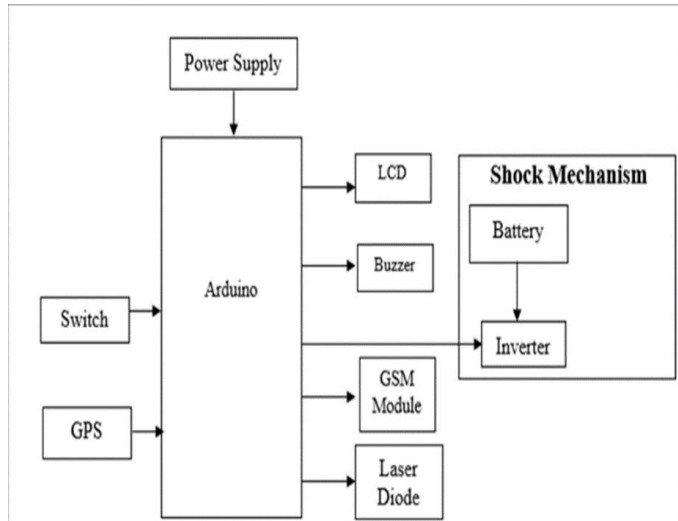

Fig 4.2: System Architecture

The main goal of this paper is to use Raspberry Pi to improve women's safety and security. Python programming is used for this purpose. A temperature sensor, heart rate sensor, GPS, and camera module are all built into the Raspberry Pi. When a woman is in danger, an alarm will be sent automatically or manually to the appropriate authorities. Furthermore, using voice information can assist women who are in risk. and because she was unable to click the button at the time, she simply said "help," and an SMS alert with the location and captured picture was sent to the guardian's/police. Fig-1 shows the block diagram for women safety using GPS and GSM modules.

4.2 Interfacing Of Gsm Module With Arduino:

Even though there are different types of GSM modules are available, we are using a SIM 900 GSM module. Only three connections are required between GSM module and Arduino to interface GSM with

Arduino.

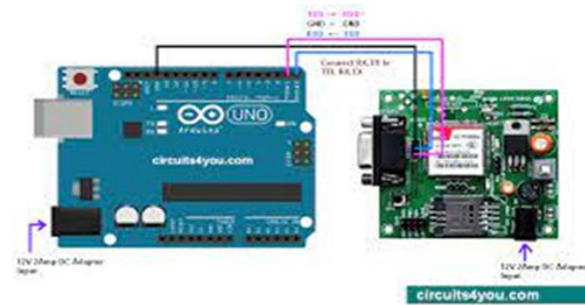

Fig 5.1: Interfacing of Arduino with GSM

Different types of output are taken from the PCB board, and it is connected with the GSM module. TTL output is for Arduino and RS232 output is for interfacing directly with the PC. For our paper we are choosing an Arduino compatible gsm module with TTL output provisions.

4.3 High Voltage Low Current Electric Shock Circuit:

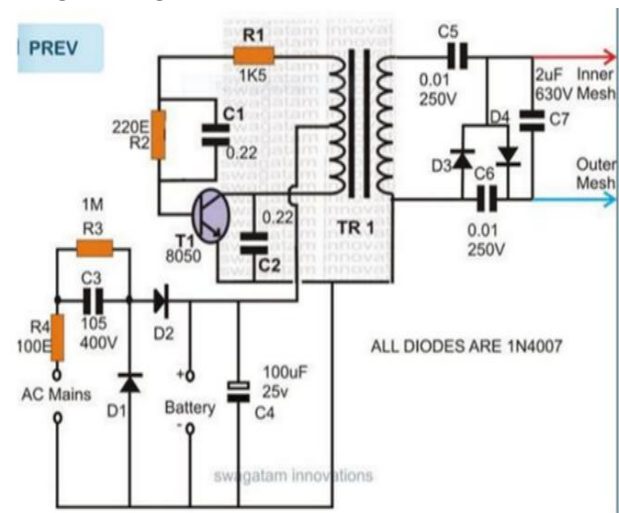

Fig 5.2.1 High voltage Low current circuit

The High voltage circuit works on the principle of blocking oscillator concept is shown in Fig.2. R1 and C1 is mainly used for determining the frequency of oscillation. While adjusting the preset the transistor will never come within the unsafe zone, it is ensured by R1. 3V DC power supply is required to operate the circuit. When power supply is given, the center tapped transformer and transistor starts oscillating at high frequency as specified before. This makes the battery current to pass across the TR1 winding. Because of switching, a high voltage is induced across the secondary winding of TR1, which is around 200v. Then the

voltage is raised to the appropriate level, such that it will generate a flying spark, which is done by a charge pump circuit used at the output of TR1. This network raises the output voltage from 200v to 600v. The bridge rectifier will rectify the high voltage and stepped up by 2uF/1KV capacitor. When the terminals are relatively close a flying spark will be generated.

### 5.3 FLOWCHART

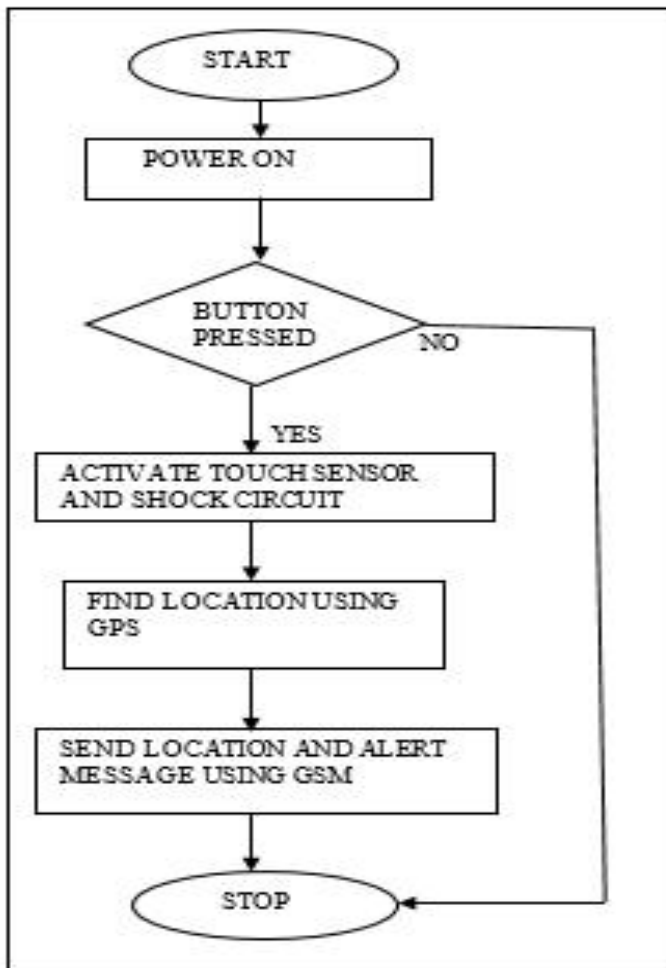

Fig 5.3.1 Flowchart of operation of device

This paper clearly uses two main modules of GSM and a microcontroller. The user when sends the messages through his phones those reaches the GSM, through the AT commands all those messages reach the microcontroller. That microcontroller takes the data in terms of bits through the Max232. That information will be transmitted to the LCD display and also a shock giver circuit which is intended to hurt the attacking

the person, due to which there is a chance for the women to escape.

### 5. HARDWARE DESIGN:

The proposed women safety device provides assistance to a woman who might be in an unsafe situation. The device is essentially ready for all the situations that might go against the will of the woman. Fig.1 shows the hardware design of the safety device. It uses AT Mega 328 microcontroller. The design comprises of fingerprint scanner to activate the device, GSM (Global System for Mobile Communications) module for sending alert messages, buzzer for alerting the environment and shock wave generator for self defence. It has a LCD that displays the message.

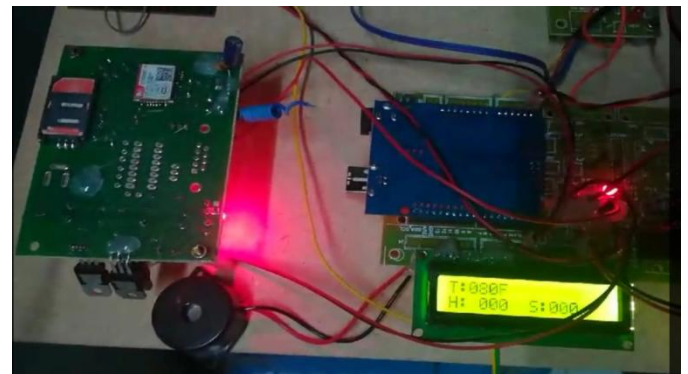

Fig 4. hardware design

The fingerprint of the woman must be registered initially and it is used to activate the device. As soon as the device is activated by the woman, it starts scanning the fingerprint of the woman for every minute. The time when no fingerprint is sensed by the scanner, the device will be triggered setting off a buzzer to alert the nearby public. As the device starts scanning the fingerprint only during emergency i.e., only when the woman senses some danger, the quality of the device is not affected. Moreover, the latitude and longitude data which is received by the GPS is delivered to both the LCD and the GSM modem which will forward the message to the woman's family/friends. Thus, even if she is knocked down from behind and is not able to trigger an alert, the device will automatically send an emergency message to all the contacts listed by the woman as ICE contacts (In Case of Emergency contact) regarding the current location

of the woman. The design also includes shock wave generator that acts as weaponry and helps woman to defend herself. Fig. 2 shows the hardware design of shock wave generator that comprises of a switch, transformer and wires.

## 6. METHODOLOGIES

### 6.1 Manual Mechanism

The process flow that occurs when the women are in a position to react is called the manual mechanism. It has a button that the woman can press when she feels threatened. The buzzer activates when the button is pushed, making a loud noise to warn anyone nearby who can assist her. The alarm system is then activated.

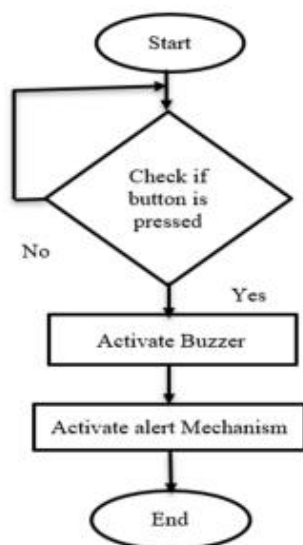

Fig 6.1: Manual mechanism

### 6.2 Automated Mechanism

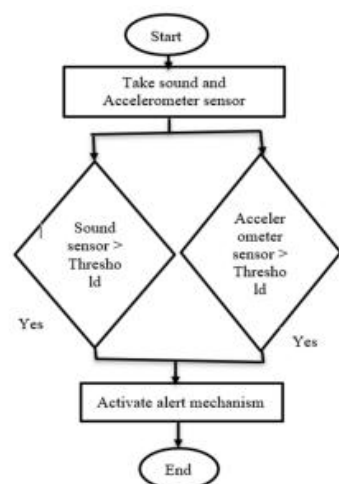

Fig 6.2.1 Automatic System

The woman may not be able to respond and use the manual mechanism in the majority of cases. As a result, use friction, temperature, and pulse-rate sensors to automate the mechanism. In order to eliminate false positives, combine the readings of these sensors. The alarm system is triggered when one of the two sensors detects an abnormality. A force sensing resistor sensor is used as a pressure sensor (FSR). The resistance decreases exponentially with a slight increase in force. The resistance value is transformed to an analogue voltage between 0 and 5 volts.

### 6.3 Alert Mechanism

During a dangerous situation, one of the above processes triggers the alarm system. When the warning system is enabled, GPS and GSM are used to transmit a message to relatives and officials containing the victim's location. For easy access, the location is sent as a Google Maps connection.

This prototype is developed with the hope that it would be capable of providing better safety to women than many devices that are available nowadays. This system consists of a Arduino Nano, SIM module, Display, Power supply, additional protection circuit, and a smart phone.

The GPS tracking [1], messaging and the alarm facility of the smart phone are also utilized. Hardware is paired with the smart phone via SIM. During normal operation, the time is displayed in the seven segment displays. If a switch is pressed then simply the location will be sent to one or more predefined numbers.

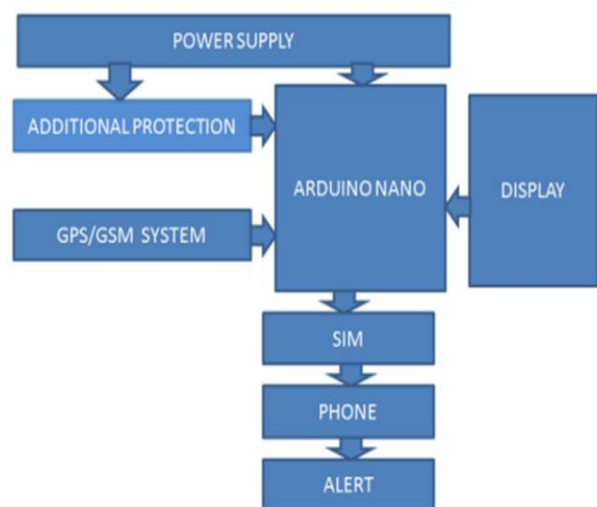

Fig 6.3.1 Alert Mechanism

## 7. RESULTS

In our proposed system whenever the victim presses the emergency button, his location link will be sent to nearby police station and registered Mobile numbers. hence, they can also get information about her status whether she is safe or not by making use of safe switch, sometimes if she requires help in seconds of time then there will be a problem, to avoid that problem partially we came up with the solution i.e., shock button. Hence every time whenever she using the system then automatically concerned information and location will be sent to their respective people and nearby police station.



Fig 6.4.1: Output of IOT base Women Safety device

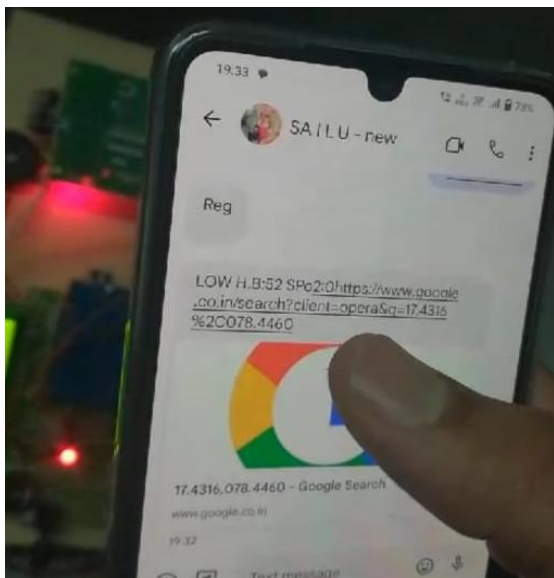

Fig 6.4.2: Output of Iot base Women Safety device

Women safety is a critical social issue in today's world. Through this work we aim to put forward an efficient and handy safety device for women. The

proposed design can handle some critical issues faced by women and will help to solve them with technologically sound and simple equipment's. The purpose of this synopsis is to improve the gender equality by providing safe environment to women in the society, and allows them to work till late nights. The band helps to get necessary help in any distance.

## 8. CONCLUSION

The main goal of creating a woman protection device is to act as a rescue and avoid any harm to women in the event of a hazard. A smart device for women's protection is planned using the proposed system, which automates the emergency warning system. This device detects and sends warnings to loved ones with the women's position coordinates without requiring her intervention in critical situations. It immediately sends an emergency alert to the family members and the nearest police station. The prototype can be carried in a variety of bags, including handbags and laptop bags. Carrying the prototype in these bags is recommended because the individual attempting to injure you might not be aware of your presence.

## REFERENCE

- [1] ShaikMazharHussain for Women Security System, 3 March 2014 2) Nishant Bhardwaj and Nitish Aggarwal for Design and Development of "Suraksha"-A Women Safety Device ,8 Number 2014
- [2] Mohamad Zikriya, Parmeshwar M G, Shanmukayya R Math, Shraddha Tankasali, Dr.Jayashree D Mallapur "Smart Gadget for Women Safety using IoT (Internet of Things)" International Journal of Engineering Research & Technology (IJERT), ISSN: 2278-0181, NCECSC - 2018 Conference Proceedings
- [3] M.S. Bhuvaneshwari, A. Shirly Edward and S.G. VijayaKumari, "GSM Based Women's Safety Device", International Journal of Pure and Applied Mathematics  
U. Jaishree Vidhya, V.K. Jothi Sree, T. Pratheeba, K. Ragapriya and B. Sathyasri, "Design and implementation of Women Safety System based on IoT technology", International Journal of Recent Technology and Engineering.