

# **Advance Heat Control System in Industry**

1. Prof. Gajendra Kumeriya, 2. Rohit Suryavanshi, 3. Tanay Shrote,  
4. Yashika Lade, 5. Minal Kale, 6. Shyam Borkar

A [1] is a lecturer at Department of Electrical Engineering in NIT Polytechnic, Nagpur & [2 to 6] is a student at Department of Electrical Engineering in NIT Polytechnic, Nagpur.

Email: rohitsurawanshi8899@gmail.com

---

## **ABSTRACT**

In modern industries, maintaining proper temperature is very important for safety, product quality, and energy efficiency. An Advance Heat Control System is designed to automatically monitor and control temperature in industrial processes using sensors, Controllers, and actuators. The system continuously measures temperature with sensors such as RTD or thermocouples and compares it with a predefined set value. If the temperature increases or decreases beyond the limit, the controller automatically operates heating or cooling devices to maintain the desired temperature.

This system reduces human effort, prevents overheating, improves machine life, and saves energy, It is widely used in industries like manufacturing, chemical plants, food processing, boilers, and furnaces. By using automation and smart control techniques, the advance heat control system increases efficiency, ensures safety .and supports reliable industrial operations.

---

## **I. INTRODUCTION**

In modern industries, temperature control plays a very important role in maintaining product quality, machine safety, and energy efficiency. Many industrial processes such as manufacturing, power plants, chemical processing, food industries, and furnaces require accurate and continuous control of heat.

An Advanced Heat Control System is a modern automatic system that monitors, controls, and regulates temperature using sensors, controllers (PLC/PID), and actuators. Unlike traditional manual systems, this system automatically adjusts heating or cooling according to the required set temperature.

This system helps to prevent overheating, reduce energy wastage, increase machine life, and improve overall productivity. It also provides real-time monitoring, safety protection, and fast response to temperature changes.

Therefore, the Advanced Heat Control System is an essential part of today's industries for safe, efficient, and reliable operation.

## **II. LITERATURE SURVEY**

### **1. Sonawane et al. (2019)**

Sonawane and co-researchers developed a temperature and humidity monitoring system using Arduino Uno and a DHT11 sensor. The system measured environmental conditions and displayed the data on an LCD screen. Their work proved that low-cost sensors and microcontrollers can be effectively used for temperature monitoring in technical and industrial environments.

## **2. Shivakumar et al. (2019)**

Shivakumar and team presented a system for measuring temperature and humidity using a DHT11 sensor connected to an Arduino controller. Their study highlighted that continuous monitoring of temperature is important for maintaining safe environmental conditions in industrial and agricultural processes.

## **3. Bentulan and Perin (2022)**

In 2022, bentulan and Perin proposed an Arduino-based digital temperature sensing system using DHT series sensors. The research focused on improving measurement accuracy and replacing traditional Analog sensors with digital monitoring systems for safety and automation applications.

## **4. Anuar, Jalaludin and Sadun (2024)**

The authors developed an IoT-based temperature and humidity monitoring system using a DHT11 sensor and Node MCU. The system transmitted real-time data to a cloud platform for remote monitoring. Their work demonstrated how industrial environments can be monitored automatically using smart sensor networks.

## **5. Ajay Krishna (2025)**

Ajay Krishna designed an automatic temperature control system using Arduino, DHT11 sensor and a DC fan. The system automatically activated the cooling fan when temperature increased beyond a preset value, helping maintain optimal environmental conditions.

### **III. SYSTEM ARCHITECTURE**

The Advance Heat Control System is designed to monitor and regulate temperature in industrial machines and motors to improve efficiency, safety, and performance. The system architecture consists of several integrated components that work together to detect heat levels and control cooling or heating mechanisms automatically.

In this system, a temperature and humidity sensor (DHT11) continuously measures the temperature of the machine or motor. The sensor sends real-time data to the Arduino UNO microcontroller, which acts as the main control unit of the system. The Arduino processes the sensor data and compares it with the predefined temperature limits.

If the temperature rises above the safe limit, the Arduino activates a relay module that controls external devices such as cooling fans or motors to reduce the temperature. Similarly, if the temperature falls below the required level, the system can activate a heating element or maintain optimal conditions.

The system also includes LED indicators and a display screen to show the current temperature and system status. Additional components like resistors, diodes, and a potentiometer help in circuit protection and signal adjustment.

This architecture ensures automatic temperature monitoring, fast response, and reliable heat control, making it suitable for industrial machines, motors, and equipment where temperature management is critical for safe and efficient operation.

#### IV. METHODS AND MATERIAL

1. **Arduino UNO** – It is the main microcontroller used to process sensor data and control the system operations.
2. **DHT11 Temperature and Humidity Sensor** – This sensor measures the temperature and humidity around the machine or motor. The sensor sends real-time data to the Arduino.
3. **Nichrome Wire (Heating Element)** – Nichrome wire is used as a heating element. It produces heat when electric current passes through it and helps simulate industrial heating conditions.
4. **Relay Module** – The relay works as an electrical switch to control high-power devices such as the heating element and cooling fan.
5. **Fan** – The fan is used as a cooling device. It reduces the temperature when the system detects excessive heat.
6. **LED Display Screen** – It shows the real-time temperature and humidity values and system status.
7. **LED Indicator** – LEDs indicate whether the heating or cooling system is active.
8. **Resistor** – Resistors are used to control current in the circuit and protect electronic components.
9. **Diode** – Diodes protect the circuit from reverse current and voltage spikes.
10. **Potentiometer** – It is used to adjust voltage or contrast of the display and fine-tune the system settings.
11. **Breadboard** – Breadboard is used for temporary circuit connections and prototyping without soldering.
12. **Adaptor (Power Supply)** – The adaptor provides the required DC power to operate the Arduino and other components.

The system works on automatic temperature monitoring and control. The DHT11 sensor continuously measures the temperature near the machine or motor. The sensor sends this data to the Arduino UNO, which processes the information and compares it with the preset temperature limit.

If the temperature increases above the safe level, the Arduino activates the relay, which turns on the cooling fan to reduce the temperature. If heating is required, the system activates the nichrome wire heating element. The LED display shows the current temperature and humidity, while LED indicators show the system status.

This automated system helps maintain the required temperature level in industrial machines, motors, and equipment, improving operational efficiency, safety, and equipment life.

#### V. HARDWARE DESCRIPTION

The hardware of **the Advance Heat Control System** is designed to **monitor and control the temperature of industrial machines and motors automatically**. The system consists of several **electronic components** that work together to **detect heat and maintain a safe operating temperature**.

**Arduino UNO** is the **main controller** of the system. It receives **temperature data from the sensor** and controls the operation of other devices such as the **relay, fan, and heating element**.

**The DHT11 temperature and humidity sensor** is used to **measure the temperature around the machine or motor**. It continuously sends **temperature data to the Arduino** for monitoring.

**A relay module** is used as an **automatic switch** to control **high-power devices**. It allows the Arduino to **turn ON or OFF the heating element and cooling fan** based on the temperature level.

The **nichrome wire** acts as a **heating element**. When **electric current flows through it, heat is generated**. This helps simulate or control **heating conditions in industrial systems**.

**A cooling fan** is used to **reduce excess heat from machines or motors** when the **temperature becomes too high**.

The **LED display screen** shows the current **temperature and system status**. **LED indicators** are used to **indicate whether the heating or cooling system is operating**.

Other components such as **resistors, diodes, potentiometer, breadboard**, and adaptor are used for **current control, circuit protection, adjustment, circuit connections, and power supply**.

This **hardware setup** provides a **simple, reliable, and cost-effective heat control system for industrial machines and motors**.

## **V. WORKING METHODOLOGY**

The Advance Heat Control System works on the principle of automatic temperature monitoring and control to maintain a safe operating temperature in industrial machines and motors.

At the beginning of the process, the power supply (adaptor) provides the required electrical power to the Arduino UNO and other electronic components in the system. The Arduino UNO acts as the central control unit, which manages all operations of the system.

The DHT11 temperature and humidity sensor continuously senses the temperature around the machine or motor. The sensor sends real-time temperature data to the Arduino UNO for processing and analysis.

The Arduino compares the measured temperature value with the predefined temperature limit programmed in the system. Based on this comparison, the controller decides whether cooling or heating is required.

If the temperature rises above the safe limit, the Arduino sends a signal to the relay module, which activates the cooling fan. The fan helps in removing excess heat from the machine or motor, thereby reducing the temperature.

If the temperature falls below the required level, the Arduino activates the nichrome wire heating element through the relay. The nichrome wire generates heat when electric current flows through it, which helps in maintaining the desired temperature.

The LED display screen continuously shows the current temperature and system status, allowing operators to monitor the system easily. LED indicators provide visual signals to show whether the heating or cooling system is active.

Additional components such as resistors, diodes, potentiometer, and breadboard support the circuit by controlling current, protecting components, adjusting system parameters, and providing proper connections.

Through this process, the system provides automatic temperature regulation, ensuring efficient operation, safety, and improved lifespan of industrial machines and motors.

## **VII. BLOCK DIAGRAM OF ADVANCE HEAT CONTROL SYSTEM**

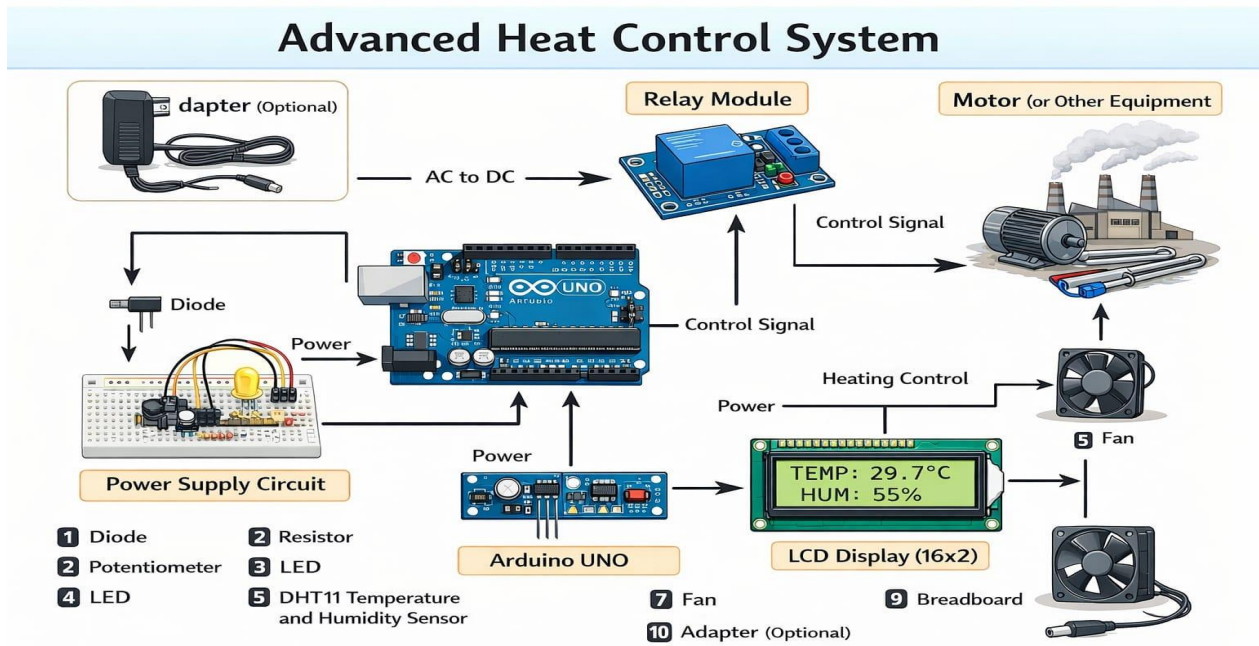

## VII. PROTOTYPE IMPLEMENTATION

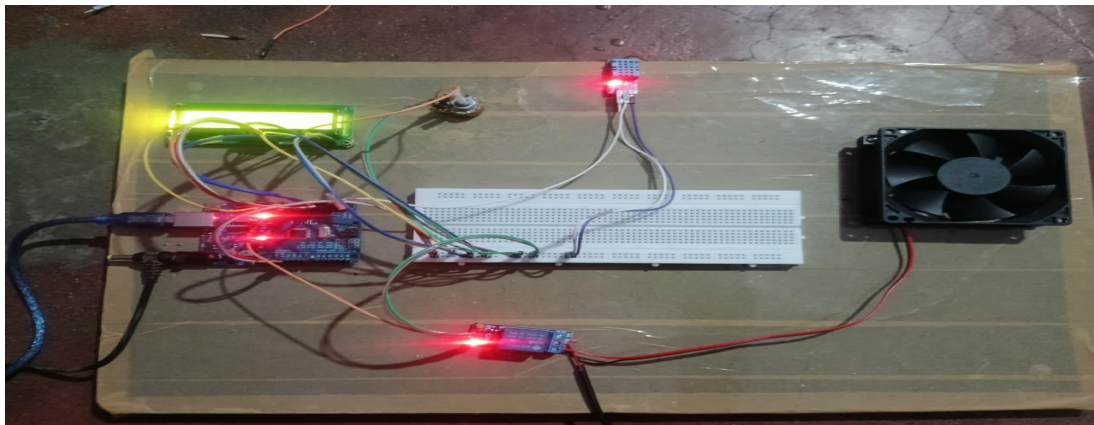

## VIII. ADVANTAGES

- 1.Prevents Overheating** – The system automatically monitors temperature and prevents machines or motors from overheating.
- 2.Improves Safety** – It protects industrial equipment from damage due to high temperature.
- 3.Increases Machine Life** – By controlling heat properly, the life of motors and machines increases.
- 4.Energy Efficient** – The system reduces unnecessary power consumption by controlling heating and cooling.
- 5Automatic Operation** – No need for continuous human monitoring because the system works automatically.
- 6.Reduces Maintenance Cost** – Prevents damage and reduces repair and maintenance expenses.
- 7.Improves Performance** – Machines operate at an optimal temperature, giving better efficiency.

**7.Real-Time Monitoring** – Temperature can be continuously monitored using sensors and display systems.

## **X. APPLICATION**

**1.Industrial Machines** – Used to control the temperature of machines during continuous operation.

**2.Electric Motors** – Protects motors from overheating and improves their working life.

**3.Manufacturing Industries** – Maintains proper temperature in production machines and equipment.

**4.Boilers and Heating Systems** – Controls heat level to ensure safe and efficient operation.

**5.Power Plants** – Monitors and controls temperature of electrical equipment and generators.

**7.Automated Industrial Systems** – Used in automation systems for automatic temperature control.

**8.Electronic Equipment Protection** – Prevents damage to sensitive electronic devices due to excess heat.

## **XI. RESULTS AND DISCUSSION**

The Advance Heat Control System was successfully designed and tested to monitor and control the temperature of machines and motors in industrial applications. The system used a temperature and humidity sensor to continuously measure the heat level and send data to the Arduino UNO controller. When the temperature increased beyond the preset limit, the controller automatically activated the cooling fan through the relay module. When the temperature returned to the normal range, the system switched off the fan to save energy. The LCD display showed the real-time temperature values, which helped in easy monitoring of the system.

During testing, the system responded quickly to temperature changes and maintained a safe operating range for the equipment. The results showed that the system can effectively prevent overheating and reduce the risk of machine damage. It also improves efficiency and safety in industrial environments by providing automatic temperature control. Overall, the developed system proved to be reliable, simple to operate, and suitable for industrial machines and motors where temperature management is important.

### **1. Technological advancements**

- Use of Arduino UNO microcontroller for automatic temperature monitoring and control.
- Integration of DHT11 temperature and humidity sensor for accurate heat detection.
- Automatic cooling system using relay-controlled fan to prevent overheating.
- Real-time temperature display on LCD screen for easy monitoring.
- Energy-efficient operation as the system works only when temperature exceeds the preset limit.
- Compact and low-cost design suitable for industries, machines, and motors.

### **2. Market Expansion & Commercialization.**

The Advance Heat Control System has a good market potential because many industries use machines and motors that generate high heat during operation. This system helps to control temperature automatically and protect equipment from overheating. It can be used in manufacturing industries, motor control panels, electrical rooms, and small-scale industries to improve safety and efficiency.

The system can also be expanded by adding multiple temperature sensors to monitor several machines at the same time. It can be upgraded with IoT technology for remote monitoring and control through mobile

phones or computers. Additional features such as alarm alerts, automatic shutdown systems, and data logging can further enhance the performance of the system.

From a commercialization point of view, the Advance Heat Control System is low-cost and easy to manufacture. It can be developed as a compact device and installed in industrial machines and motors. With proper design, packaging, and marketing, this system can become a useful commercial product for industrial automation and equipment protection.

- The system has good market demand in industries to prevent machine overheating.
- It can be expanded by adding more sensors and IoT-based monitoring.
- The system can be used in motors, machines, and industrial control panels.
- It is low-cost and easy to manufacture for industrial use.
- It has good potential for commercialization in the industrial automation market.

### **3. Sustainability & Environmental Benefit.**

- The system reduces energy waste by operating the cooling fan only when the temperature increases.
- It helps in protecting machines and motors, which increases their lifespan.
- It reduces overheating and prevents damage to industrial equipment.
- Lower energy consumption helps in reducing environmental impact.
- The system supports sustainable and efficient industrial operation.

### **4. Challenges & Research Opportunities.**

- Accuracy of temperature sensors can be affected by environmental conditions.
- System reliability may reduce if electronic components fail.
- Research can focus on using more accurate and advanced sensors.
- Integration with IoT and wireless monitoring can be further developed.
- Future research can improve automation and smart control features.

## **XII. CONCLUSION**

The Advance Heat Control System is an effective solution for monitoring and controlling the temperature of machines and motors in industrial environments. The system uses sensors and a microcontroller to detect heat and automatically activate the cooling system when the temperature exceeds the safe limit. This helps in preventing overheating, improving machine safety, and increasing equipment life. The system is simple, low-cost, and easy to implement in industries. Overall, the Advance Heat Control System improves efficiency, reduces energy waste, and provides reliable temperature management for industrial applications.

## **XIII. REFERENCES**

1. S. Kaushik, Y. S. Chouhan, N. Sharma, and S. Singh, "Automatic fan speed control using temperature and humidity sensor and Arduino," *International Journal of Advance Research, Ideas and Innovations in Technology*, vol. 4, no. 2, pp. 1–5, 2018.
2. A. M. Akilesh, R. Shanmuga Sundaram, V. S. Naveen Kumar, and M. Shenbagapriya, "IoT based humidity and temperature monitoring system using Arduino Uno," *International Journal of Engineering Research & Technology*, vol. 10, no. 8, pp. 200–205, 2022.
3. K. P. Kuria, O. O. Robinson, and M. M. Gabriel, "Monitoring temperature and humidity using Arduino Nano and DHT11 sensor with real-time data logger," *International Journal of Engineering Research & Technology*, vol. 9, no. 12, pp. 350–355, 2020.
4. S. Rumalutur and A. Mappa, "Temperature and humidity monitoring system with Arduino R3 and DHT11 sensor," *Electro Luceat Journal of Electrical Engineering*, vol. 5, no. 2, pp. 40–47, 2019.

5. R. N. Sonawane, S. A. Ghule, P. A. Bowlekar, and H. A. Zakane, "Design and development of temperature and humidity monitoring system," *Agricultural Science Digest*, vol. 39, no. 2, pp. 114–118, 2019.
6. A. V. Nale, R. P. Wagatkar, S. N. Majgawale, and K. A. Lanje, "Temperature based fan speed control using Arduino," *International Journal for Research in Applied Science & Engineering Technology*, vol. 13, no. 1, pp. 520–525, 2025.
7. P. Senthil, "Effective monitoring of temperature and humidity in real-time wireless sensor system," *Asian Journal of Science and Applied Technology*, vol. 7, no. 1, pp. 25–30, 2018.
8. W. S. Lee, "A low-cost cryogenic temperature measurement system using Arduino microcontroller," arXiv preprint arXiv:1910.09111, 2019.
9. E. O. Rosa, M. P. Silva, and R. T. Souza, "An embedded system for monitoring industrial air dehumidifiers using a mobile Android application," arXiv preprint arXiv:2008.11123, 2020.
10. Muhammad Ali Mazidi, J. G. Mazidi, and R. McKinlay, *The 8051 Microcontroller and Embedded Systems*, 2nd ed. New Delhi, India: Pearson Education, 2008.
11. I. J. Nagrath and D. P. Kothari, *Electrical Machines*, 5th ed. New Delhi, India: McGraw Hill Education, 2010.
12. Muhammad Ali Mazidi, S. Naimi, and S. Naimi, *The AVR Microcontroller and Embedded Systems Using Arduino*, Pearson Education, 2014.
13. Arduino, "Arduino UNO Rev3 Datasheet," Arduino Documentation, 2023.
14. DHT11 Temperature and Humidity Sensor Datasheet, Aosong Electronics Co., Ltd., 2022.
15. Institute of Electrical and Electronics Engineers, *IEEE Standard for Temperature Monitoring in Electrical Equipment*, IEEE Standard Publication.

**International Journal of Electrical Engineering and Ethics- Volume 9  
Issue 2, March-April - 2026**